

MOVING iMAGE TECHNOLOGIES

INSTRUCTIONS

FOR

INSTALLATION, OPERATION, AND MAINTENANCE

OF

MS2 Digital Pedestal

Manual Version 0.1

MOVING iMAGE TECHNOLOGIES, LLC.
17760 Newhope St.
Fountain Valley, CA
Telephone: (714) 751-7998
Fax: (714) 429-7717
www.movingimagetech.com

Manual MS2 Pedestal

The information in this document is subject to change without notice and does not represent a commitment on the part of Moving Image Technologies (hereinafter referred to as MIT). MIT does not assume responsibility for errors that may appear in this document. MIT or its subsidiaries, designated representatives and any other vendor of the XLC Console are not responsible in any way for any liabilities or loss resulting from the use or misuse of this document.

Copyright © 2010 by MIT
All Rights Reserved

All copyrights and trademarks are the property of their respective owners.

MOVING iMAGE TECHNOLOGIES, LLC.
Fountain Valley, CA
Telephone: (714) 751-7998
www.movingimagetech.com

TABLE OF CONTENTS

<u>Section</u>	<u>Page</u>
1. INTRODUCTION	2
1.3 SAFETY	2
2. GENERAL DESCRIPTION	3
3. INSTALLATION PROCEDURES	4
4. MAINTENANCE	7
APPENDIX A: ASSEMBLY DIAGRAMS AND PARTS LISTS	8

1. INTRODUCTION

1.1 CONTENTS OF THE MANUAL

This manual contains installation, operation, and operator maintenance procedures for the MiT MS2 Pedestal. The material covered includes:

- Section 2: General Description
- Section 3: Installation and Assembly
- Section 4: Maintenance

Additional reference information is contained in the appendix.

1.2 SPECIAL NOTICES

Two kinds of specific notices are used within this manual to emphasize information.

1.2.1 WARNING

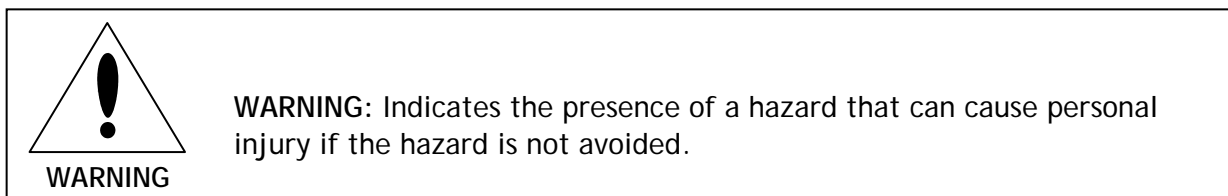

1.2.2 CAUTION

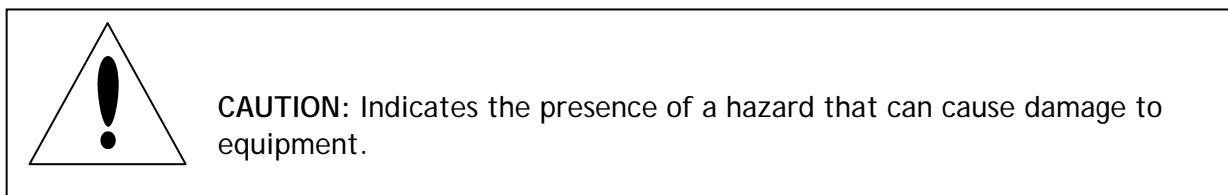

1.3 Safety Concerns

- ✓ Exercise care in placing the pedestal, serious injury can result from the unit falling or tipping.
- ✓ Disconnect the AC lines before working on anything inside the pedestal.

2. GENERAL DESCRIPTION

The MIT MS2 Pedestal is a commercial-grade support chassis for Digital cinema projectors and equipment. It is designed to hold up to 400 lb, i.e. one large projector. The pedestal may be configured with different options and accessories, depending on the customer and the specific requirements as defined by the purchase order. This manual applies to the basic configuration of the unit, without additional equipment installed.

Safety note: overloading the pedestal may result in serious personal injury or damage to equipment.

2.1 Physical Specifications

See Figure 2-1 for dimensions and Table 2-1 for weights of finished pedestals.

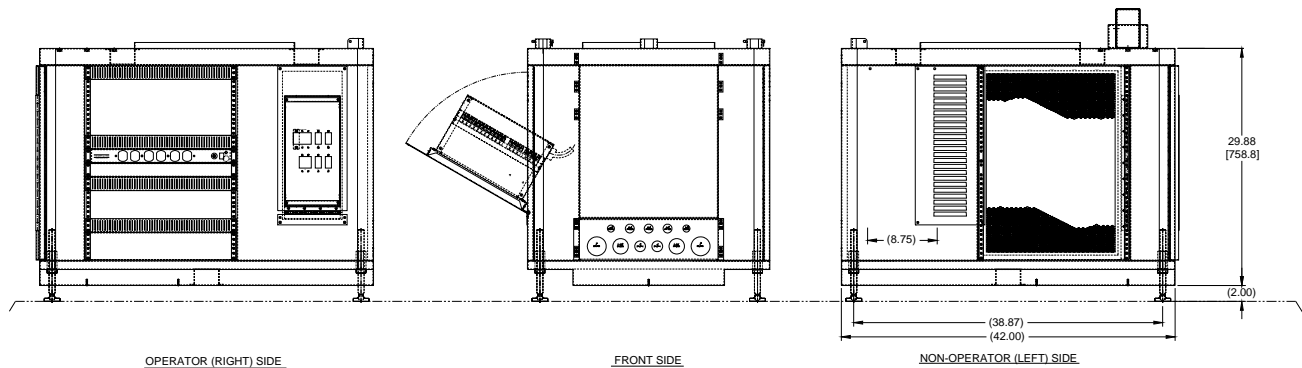

Figure 2-1: Outline, all models (typical configuration shown)

Table 2-1:

Model	Weight (lbs) [kg]
MS2	TBD

3

3 INSTALLATION



CAUTION: Users are urged to read this instruction manual thoroughly and understand the procedures described herein before assembling and installing the system.

3.1 UNPACKING

To unpack, remove and discard any straps, cardboard and other shipping materials from the pedestal (however leave the foam pieces on the feet until placed in the location). Carefully inspect the system for any shipping related damage. If damage is found notify shipping agent immediately. If the shipment includes optional equipment also unpack those items.



If units were shipped stacked 2 high, lift the upper unit off with its 4 foam pieces remaining on the feet. Set the unit on the floor with four foam pieces intact on the feet until it's placed near its final installation point. Do not remove the foam or extend the leveling feet until the unit is in place, including being lifted onto a platform, stand, or plinth, if applicable.

3.2 LOCATING

Move the pedestal to its final location. Get it as close as possible to that location before discarding the protective foam corners on the feet. Do not install any equipment in the rack area or a projector on top of the pedestal prior to placing it in its final location. The pedestal isn't intended to be moved after additional equipment has been installed into or onto it.

When placing the pedestal in position, bear in mind the relative locations of equipment racks or other pieces of the system that will be installed. Allow sufficient room between the front of the pedestal and any walls or projection ports, to allow for the overhang of the projector lens. This will usually be a minimum of 12 inches or 30cm. Allow additional space if anamorphic lens attachments, 3D systems, or a large model projector is to be used.

Once the MS2 Pedestal has been placed in the appropriate location at the desired auditorium projection port, remove the foam pieces from the feet, as well as any

remaining protective plastic or cardboard shipping materials. Internally there may be tie wraps and other shipping restraints that must be removed.

Prior to mounting a projector on the pedestal or loading any equipment into its rack area, extend the leveling feet far enough so they can easily be adjusted with a wrench later, i.e. approximately 1 inch or 25mm (see Figure 3-1). Extending the feet may require tipping the unit up on one side, which is why this should be done before adding any equipment to the pedestal.

Don't attempt final leveling of the pedestal at this time, that will be done once a projector is installed.

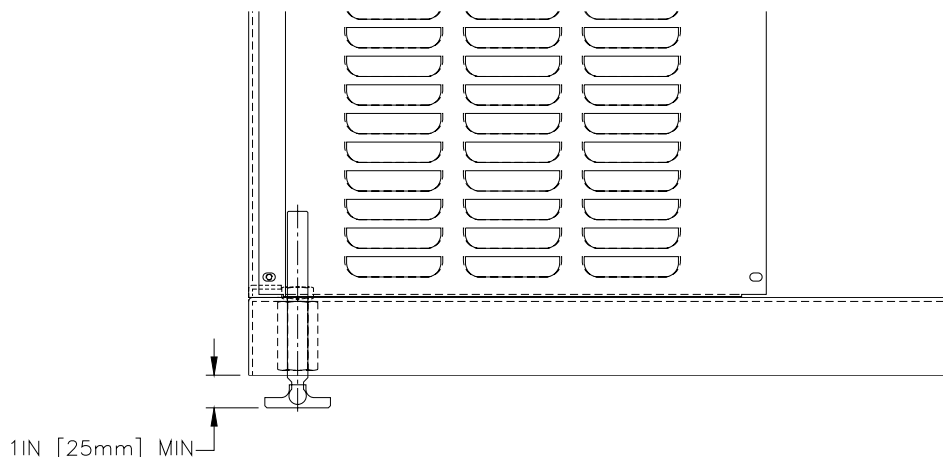



Figure 3-1

3.3 INSTALLING

The MS2 Pedestal comes from the factory completely assembled. The on-site installation consists of aligning the system to the screen with the leveling feet, installing the extender block for the rear projector feet (if required) and the installation of the projector including electrical wiring and exhaust. For details on projector installation, consult the projector manual.

3.3.1 Earth Ground & Electrical Wiring



CAUTION: Local and national electrical codes should be observed at all times.

The MS2 Pedestal includes a ground stud for connection to earth ground. All other electrical wiring is dependent on the equipment installed, and is the responsibility of the contractor performing the electrical connection.

3.3.2 Pedestal Leveling

It's easiest to adjust the leveling feet on the pedestal to an approximate position prior to placing the projector on the pedestal. Use a carpenter's level to adjust the level of the pedestal side-to-side to ensure the system is level and is stable to the floor. Don't worry about fore-aft leveling at this time, except if you know you have a down angle for the optical axis, you may adjust the rear pedestal feet slightly higher before placing the projector on it.

3.3.3 Projector Leveling Feet and Extender Block

The extender block for the rear projector feet provides from 4 to 12 degrees of downward tilt. If the down-angle for the auditorium is less than 4 degrees you won't need the tilt block, you can discard it or save it for another installation. If the down angle is greater than 4 degrees but less than 8 degrees, the extender block may be used laying on its flat side to avoid unnecessarily extending the projector feet. If the down angle is greater than 8 degrees, the extender block may be placed on its narrow side to provide maximum elevation at the rear. The down angle and need for the extender block should be determined prior to placing the projector on top of the pedestal.

Once the projector is placed on the pedestal, the projector feet may be adjusted to fine-tune the down angle and for a stable platform, i.e. with all 4 feet in the same plane so the unit doesn't rock.

4. Maintenance



CAUTION: Disconnect AC feeds to the pedestal prior to performing any maintenance.

The only maintenance normally required for the MS2 pedestal is servicing the equipment installed in its rack area. However you should periodically check to be sure the vented side panels aren't clogged or obscured by dirt, papers, or rags.

If the unit includes a power distribution unit, periodically check the electrical connections at breakers and terminal blocks for tightness.

It's also a good idea to periodically check panel screws and other hardware for tightness, to avoid annoying rattling and buzzing noises. Also be sure to check the mounting screws on fans, fan guards, or those nearby fans and other sources of vibration.

Appendix A

Appendix A: Diagrams, Parts Lists & other Reference material

<u>Description</u>	<u>Page</u>
Standard Warranty	9
Part Numbers & Accessories	11

Standard Product Warranty

WARRANTY, DISCLAIMERS AND LIMITATION OF LIABILITY

Unless otherwise noted, all Moving Image Technologies products are covered by the warranty set forth in the following paragraphs.

The warranty is extended only to the purchaser of the Products directly from Moving Image Technologies, or an authorized dealer of Moving Image Technologies, as new merchandise. For a period of twelve (12) months from the date of original delivery to Buyer, the Products are warranted to be free from functional defects in materials and workmanship, provided they are operated under condition of normal use, and that repairs and replacements are made in accordance herewith. Moving Image Technologies does not warrant consumable components. The foregoing warranty shall not apply to Products that have been disassembled, altered or repaired other than by Moving Image Technologies (or by a Moving Image Technologies certified technician) or if the Product has been subject to abuse, misuse, negligence or accident.

Moving Image Technologies sole and exclusive warranty obligation and Buyer's sole and exclusive warranty consists of Moving Image Technologies, at its option, repairing or replacing free of charge Products: (a) which contain a defect covered by the above warranty; (b) which are reported in writing to Moving Image Technologies not later than seven (7) days after the expiration of the twelve month warranty period; (c) which are returned to Moving Image Technologies promptly after discovery of the defects; and (d) which are found to be defective by Moving Image Technologies upon examination. Buyer shall pay all transportation charges.

Moving Image Technologies shall not be otherwise liable for any damages, including, without limitation, loss of profits or overhead, reimbursement, personal injury or property damage. The aforesaid warranty obligation of Moving Image Technologies constitutes its sole liability, and under no circumstances, shall the maximum liability of Moving Image Technologies under any legal theory (e.g. Contract, warranty, negligence, promissory, estoppels, strict liability, misrepresentation, tort) and for any reason whatsoever (e.g. Defect, delay or otherwise) exceed the purchase price of the defective part, regardless whether the claim is asserted by buyer or any other person or entity. The liabilities of Moving Image Technologies, as above set forth, shall not be extended because of advice given by it in connection with the design, installation or use of the products or parts thereof.

There are no express or implied warranties which extend beyond the warranties set forth above. Moving Image Technologies makes no warranty of merchantability or fitness for a particular purpose with respect to the products or any parts thereof.

This warranty is subject to change at any time without notice.

CONTACTING MiT

To order parts or request information from MiT, use the address, telephone number, or fax number given on the inside front page of this document. When contacting MiT be prepared to provide:

- Model and serial number.
- Part name and part number, as shown in this manual.
- Purchase order number.

The purchase order number is essential for replacement parts requested under warranty. MiT issues credit for defective parts received. Please request a Return Authorization number from MiT for any defective parts.

Part numbers & Accessories

A000310-001	MS2 Pedestal Assy (30" high)
A000176-001	Power Distribution unit, with 2-pole Projector breaker
A000176-002	Power Distribution unit, with 3-pole Projector breaker (other PDU configurations available, contact MIT)
C003110-001	Foot Lock Bracket, Pedestal to floor (4 req'd)
C003184-001	Extender block/riser, Projector rear (included with the pedestal)
C003193-001	Foot Lock Bracket, Projector to Pedestal (2 req'd)